

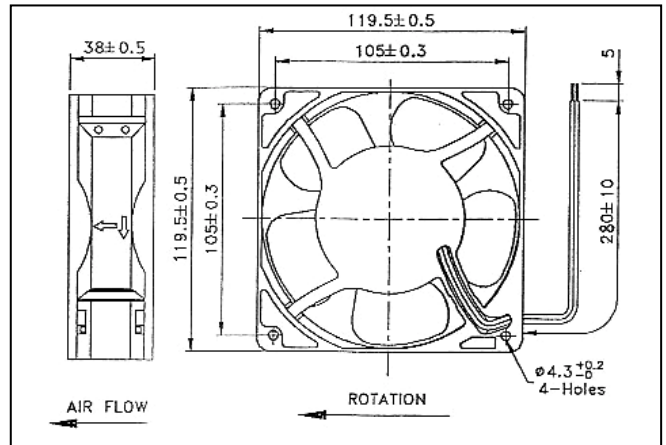

**DRAWING**



**FEATURES**

- Glass fibre reinforced plastic (PBT) fan casing and impeller.
- Brushless dc motor. I.C. protected against running overload.
- Electrical connection via 2 leads UL1007 AWG24, 280mm long.
- Rated temperature range:  
 Ball bearing from -20°C to +70°C  
 Sleeve bearing from -10°C to +60°C  
 Hypro bearing from -10°C to +60°C
- Service life L10:  
 Ball bearing 70,000 hours at 40°C  
 40,000 hours at t max  
 Sleeve bearing 50,000 hours at 40°C  
 35,000 hours at t max  
 Hypro bearing 70,000 hours at 40°C  
 40,000 hours at t max
- Weight 250g.

Please refer to our terms of sales including our warranty and limited liabilities clauses.

**AIR FLOW CURVES**

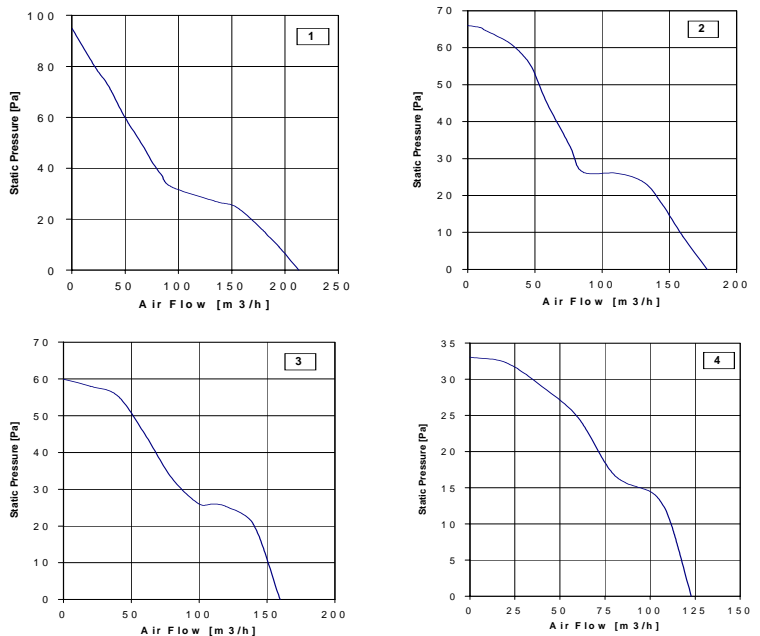

Model	Diagram	Bearing #			Rated Voltage [V]	Input Power [W]	Speed [rpm]	Air Flow [m3/h]	Static Pressure [Pa]	Noise [dB(A)]	Approvals		
		S	H	B							UL	CUL	TUV
D12B04SW#Z00	1	★	★	★	12	9.6	3200	213	95	46.0	S,H,B		
D12B04HW#Z00	2	★	★	★	12	6.0	2800	178	66	42.8	S,H,B	B	
D12B04MW#Z00	3	★	★	★	12	4.2	2540	160	60	41.0	S,H,B		
D12B04LW#Z00	4	★	★	★	12	2.9	1950	123	33	32.9	S,H,B		
D12B05SW#Z00	1	★	★	★	24	9.4	3200	213	95	46.0	S,H,B		
D12B05HW#Z00	2	★	★	★	24	7.7	2800	178	66	42.8	S,H,B		
D12B05MW#Z00	3	★	★	★	24	5.5	2540	160	60	41.0	S,H,B		
D12B05LW#Z00	4	★	★	★	24	3.4	1950	123	33	32.9	S,B		
D12B07HW#Z00	2	★	★	★	48	9.6	2800	178	66	42.8	S,H,B		
D12B07MW#Z00	3	★	★	★	48	6.7	2540	160	60	41.0	S,H,B		
D12B07LW#Z00	4	★	★	★	48	4.8	1950	123	33	32.9	S,H,B	H	

“#”: S=Sleeve; H=Hypro; B=Ball



Fandis S.p.A. Via per Castelletto, 69  
 28040 Borgoticino (No) Italy  
 Tel. +39 0321 96.32.32 Fax +39 0321 96.32.96  
 info@fandis.it • www.fandis.it

COMPANY WITH QUALITY SYSTEM  
 CERTIFIED BY DNV  
**ISO 9001/2000**

All specifications, data and drawings are subject to change without notice and are approximate.

CSV-J30/3